

BACON THEATRE

TECHNICAL SPECIFICATION



**BACON
THEATRE**
DEAN CLOSE

We hope the following information is useful in planning your productions.

Additional Hire Items are available from our hire partners subject to a 10% additional charge to incoming companies

Items Marked ** are Chargeable back to the Hirer

If you have any queries, please feel free to get in touch.

CONTACT

George Humphries – Theatre and Technical Manager
george@bacontheatre.co.uk
07377964846

Jess Purvis – Theatre Technician
jess@bacontheatre.co.uk

Alex Jackson – Technician

Peter Jackson – Technician

Will Maeers – Technician

Jonah Starkey – Technician

Archie Webb – Technician



STAGE

DIMENSIONS

| | |
|-------------------|----------------------------|
| Proscenium Width | 11.43m |
| Proscenium Height | 5.66m |
| Stage Depth | 11.00m |
| Thrust Depth | 2.75m |
| Thrust Width | 9.00m |
| Stage Height | 0.62m |
| Stage Width | 18.0m (SL wall to SR wall) |
| Grid Height | 10.26m |

CLEARANCE UNDER FLY FLOOR GALLERY 3.06m (SR Wing)

ACCESS

Access is either via dock doors or level load in from front entrance of theatre. There is an exterior ramp down the side of the auditorium, onto stage.

| | |
|---------------------------|-------|
| Dock Door Width | 2.71m |
| Dock Door Height | 3.62m |
| Dock Height (from ground) | 2.00m |
| Dock Width | 3.00m |

Articulated Lorries can be accommodated on site with prior notice but they **DO NOT** fit in the dock. Smaller rigid lorries do fit.

BACON THEATRE

TECHNICAL SPECIFICATION



**BACON
THEATRE**
DEAN CLOSE

MASKING/ DRAPES/ HARDWARE

| | | |
|-----------------------------------|----|-------------------------|
| Black Tabs on Manual Tab Tracks | 1 | |
| Operated by a pulley Stage Left | | |
| House Header Fixed to Grid | 1 | |
| Black Legs | 10 | (x5 each side of stage) |
| Black Border | 3 | (on Hemp 4,5,6) |
| Black Hard Masking Flats | 2 | (Each side, Upstage) |
| Black Tabs on Manual Swipe Tracks | 1 | |
| White Cyclorama | 1 | |
| Stage Weights | 12 | |

STAGING

Flat wooden stage floor painted matte black.
Stage floor may NOT be re-painted.

Black Dance Floor** – please contact to discuss

| | |
|-----------------------------------|----|
| 8x4FT Prolyte Litedeck Standard** | 10 |
|-----------------------------------|----|

FLYING

| | | |
|---------------------------------|---|--------------------------|
| 4 Line Hemp Bars (SWL 50kg) | 6 | (3 of which are borders) |
| Hand Winch Bar (SWL 200kg) | 1 | |
| Motorized Winch Bar (SWL 200kg) | 4 | |

BACON THEATRE

TECHNICAL SPECIFICATION



**BACON
THEATRE**
DEAN CLOSE

POWER

Stage Left (DSL):

- 32A Single Phase 1

Stage Right (DSR):

- 32A Single Phase 3
- 63A Three Phase 1

PROMPT DESK/ COMMS

Located Stage Left

Camera feed of stage and auditorium

Wired Comms available – SL, SR, Fly Floor, Mix Position, Tech Box, Pit

DRESSING ROOMS

2 large dressing rooms with 1 large green room.

Maximum capacity 80 Persons.

WC facilities available in each dressing room.

BACON THEATRE

TECHNICAL SPECIFICATION



**BACON
THEATRE**
DEAN CLOSE

LIGHTING

CONTROL

| | |
|----------------------|---|
| ETC Ion xe20 | 1 |
| Touchscreen Monitors | 2 |

EQUIPMENT

| | |
|--|----|
| ETC ColourSource SPOT 15-30 Zoom | 12 |
| ETC ColourSource SPOT 26 Zoom | 8 |
| Briteq BT Theatre 200TW Fresnel | 20 |
| Martin Rush Par 2 RGBW Zoom | 20 |
| ETC D40 Vivid-R11 Direct | 6 |
| Prolights Studio Cobbs FC LED Wash | 4 |
| Showtec Stage Blinder 2 | 4 |
| Martin Mac 301 LED Wash | 4 |
| Martin Mac 250 Entour | 4 |
| Generic Par64 | 5 |
| ETC Source 4 junior 25-50 Zoom | 8 |
| Robert Julliat Buxie 575w Follow Spots 2** | |
| 1kW Fresnel's | 18 |
| Le Maitre MVS Hazer | 1 |

There is a limited selection of Gobo's, holders and Iris'.

8 booms are also available on prior arrangement.



CIRCUITS

Total – 120 ways of dimming

5 Zero88 Chilli Pro 24-10i (capable of dim or hot power)

Each Facility Panel has:

- 16A IWB's
- DMX outlet's patchable as Universe 1 or 2
- Cat5e outlet

36 Circuits FOH

FOH Bar 1: Circuits 1-12, DMX 1+2, Show Data 1

FOH Bar 2: Circuits 13-24, DMX 3+4, Show Data 2

SR Slips: Circuits 25-28, DMX 5+6, Show Data 3

Circle Rail: Circuits 29-32, DMX 7+8, Show Data 4

SL Slips: Circuits 33-36, DMX 9+10, Show Data 5

60 Circuits Overhead

LX1: Circuits 37-48, DMX 11+12, Show Data 6

LX2: Circuits 49-60, DMX 13+14, Show Data 7

LX3: Circuits 61-72, DMX 15+16, Show Data 8

LX4: Circuits 73-84, DMX 17+18, Show Data 9

LX5: Circuits 85-96, DMX 19+20, Show Data 10

24 Circuits on stage

DSR: Circuits 97-102, DMX 21+22, Show Data 11











DSL: Circuits 103-108, DMX 23+24, Show Data 12

USR: Circuits 109-114, DMX 25+26, Show Data 13

USL: Circuits 115-120, DMX 27+28, Show Data 14



Symbol key

-  Rush Par 2
-  RGBW
-  BT-Theatre 200TW
-  ColorSource
-  Spot Zoom
-  Selador Classic
-  Par64 (5)
-  StudioCob FC (4)
-  ColorSource Spot 26°
-  MAC 301 Wash (4)
-  Stage Blinder 2

Measurements

- LX1: 0.6m
- SCREEN: 2.2m
- HEMP 2: 3.0m
- LX2: 4.1m
- HEMP 4: 5.0m
- HEMP 5: 6.0m
- LX3: 6.6m
- LX4: 7.5m
- LX5: 8.7m

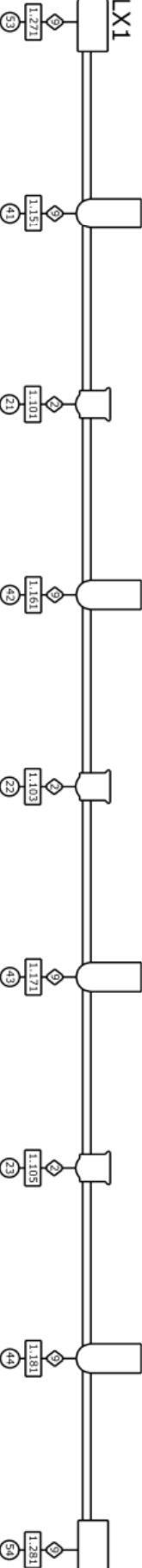
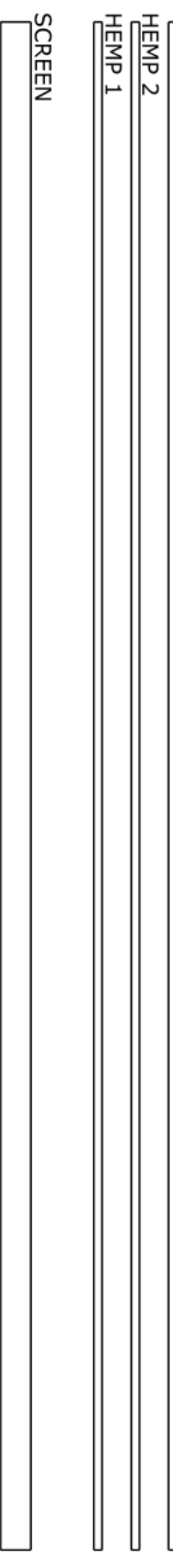
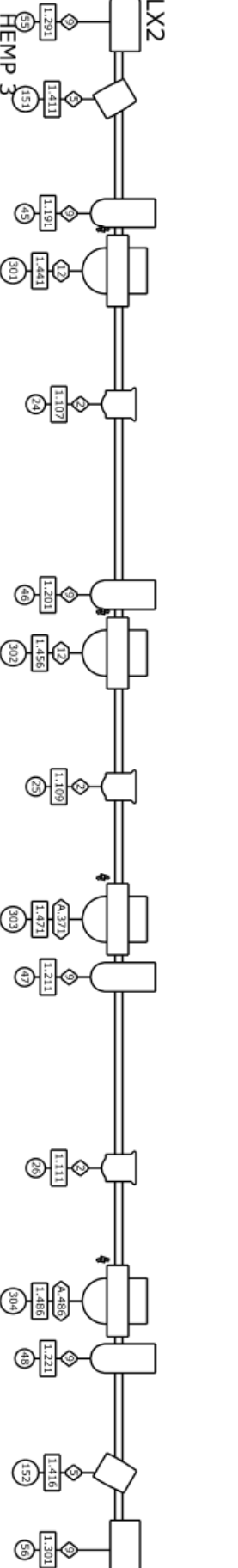
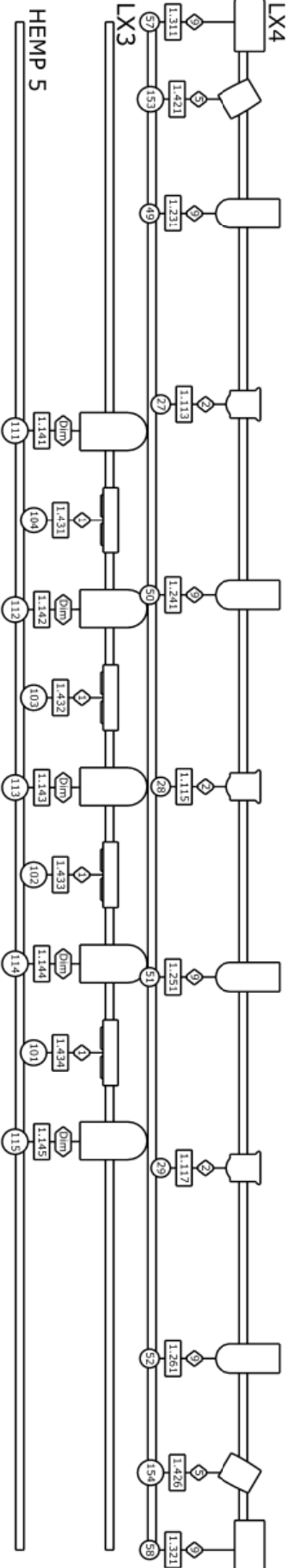
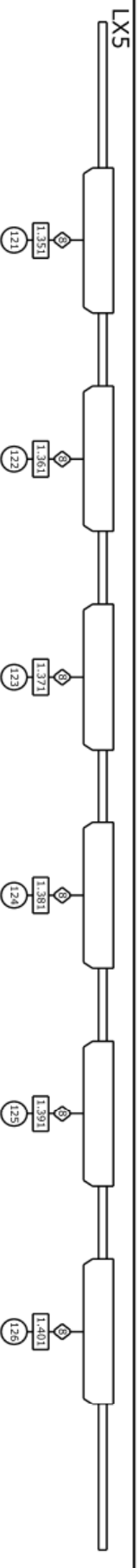

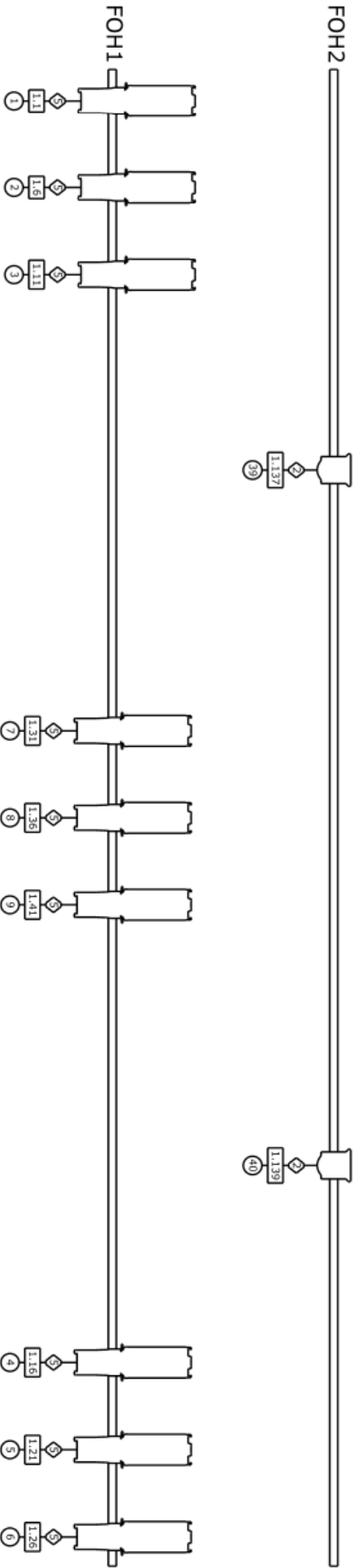

Symbol key

- ColorSource Spot Zoom 15°-30° (9)
- ColorSource Spot 26° EDLT (4)

- BT-Theatre 200TW (2)

Measurements (from Stage Level)

FOH2: 11.1m
 FOH1: 15.6m



BACON THEATRE

TECHNICAL SPECIFICATION



**BACON
THEATRE**
DEAN CLOSE

SOUND

CONTROL

| | |
|---------------------|---|
| Allen & Heath SQ6 | 1 |
| Allen & Heath DX168 | 2 |

PA SYSTEM

| | | |
|----------------------------|---|-------------------------|
| D&B E12-D Loudspeakers | 4 | (Stalls LR, Balcony LR) |
| D&B D6 Amplifier 2 Channel | 1 | |
| RCF Art712s | 6 | (Foldback) |

MICROPHONES

| | |
|-----------------------------------|----|
| Shure SM58 Dynamic Vocal Mic | 8 |
| Shure SM57 Dynamic Instrument Mic | 5 |
| Behringer C2 Condenser Mic | 12 |
| AKG Session 1 Drum Mic Set | 1 |
| Sennheiser EW-D Receiver | 4 |
| Sennheiser EW-D 835-S Handheld** | 4 |
| Sennheiser EW-D SK Bodypack** | 4 |

MIX POSITION

The auditorium mix position is central at the rear of the stalls. For this position seats 7-13 on both rows M & N have to be removed (14 seats on total – 5 seats wide by 2 rows).

BACON THEATRE ***TECHNICAL SPECIFICATION***



**BACON
THEATRE**
DEAN CLOSE

PROJECTION

EQUIPMENT

Panasonic RZ120 12,500 1-Chip DLP, WUXGA, Laser Projector**
Samsung BluRay DVD Player

SCREENS

| | |
|--------------------------------|---|
| Motorized 9m Projection Screen | 1 |
| 14ft Fast Fold Screen | 1 |